

CUB-0001

Transducer Back-Up Control



- Transducer Back-Up
- Single and Dual Float Operation
- Alarm Output
- Adjustable Time Delays
- Alternating Feature
- De-Bounce Delay
- Removable Terminal Blocks
- Indicating LEDs
- Power Off Alarm Reset



Connections

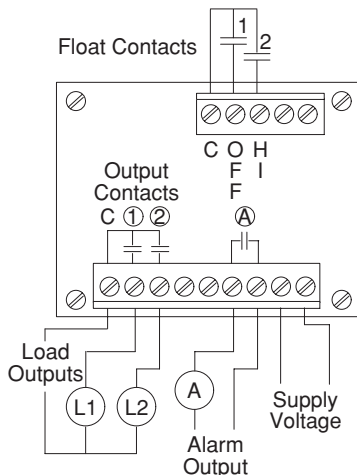

Operation

The CUB-0001 has been designed to operate as a Back-Up Controller to a transducer based system. If the transducer fails, the Back-Up Controller will allow the system to continue to operate based on a single or dual float switch inputs and activate an alarm contact.

Single Float Input

With supply power available, when the float switch input closes, a time delay is initiated. If the switch stays closed longer than the time delay, the output to pump motor #1 is energized and the alarm contact closes. When the float switch input opens, a second time delay is initiated. If the float switch remains open when the second time delay is completed the Pump output will open. The alarm contact will remain energized until power is removed and re-applied with no float switches closed.

On the next cycle, pump #2 will be started first, providing for alternation.

Dual Float Inputs

With supply power available, when the "HI" float switch input closes, the output to pump motor #1 is energized, the alarm contact closes and a time delay is initiated. If the "HI" input stays closed longer than the time delay, the output to pump motor #2 is energized. If the "HI" float switch input opens before the time delay is completed, the lag pump motor is not activated. When the "OFF" float switch input opens, all pump motor outputs are de-energized. The alarm contact will remain energized until power is removed and re-applied with no float switches closed.

On the next cycle, pump #2 will be started first, providing for alternation.

Specifications

Electrical

Line Voltage:
24V AC/DC, $\pm 10\%$
115 or 230VAC, $\pm 10\%$, 1 ϕ , 50/60Hz
Inputs: Normally Open (NO) contact or Solid State (NPN)

Power Up Delay: 5 Sec., Fixed
De-Bounce Delay: 5 Sec., Fixed
Second Pump Delay: 5 Sec., Fixed
Contact Ratings:

10 Amps Total Unit Rating
5 Amps @ 240VAC, per contact
10 Amps @ 120VAC, per contact
100,000 Full Load Electrical Cycles
10,000,000 Mechanical Cycles

Physical

Mounting: Surface
Termination: Screw Terminals Removable (Plug-In)
Packaging: Dust Cover
Weight: 2 Lbs. Approx.

Ambient Temperatures

Operating: 0°C to 65°C
Storage: -30°C to 85°C

Dimensions

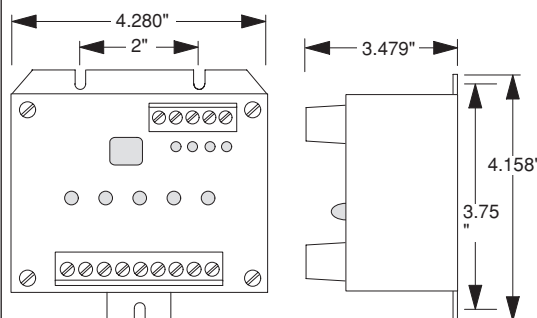

Ordering Information

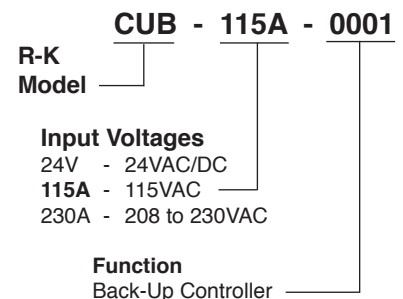



Single Float Operation:

With power applied to the Back-Up Controller when the float switch closes, the output to the lead pump will be energized and Time Delay B will be initiated. If the float switch remains closed and Time Delay B times out, the output to the lag pump will be energized.

When the float switch opens, indicating that the tank is being pumped down, Time Delay A is initiated and the output to the lead pump (and the lag pump, if it was energized) will remain energized. After the Time Delay A has been completed and the float switch is still open, the output to the pump(s) will de-energize.

If the float switch re-closes during Time Delay A, the timer is reset and the output(s) that is energized remains energized. When the float switch re-opens, Time Delay A will start again. At the completion of the time delay, the pump output(s) will de-energized. After the Time Delay A is over and the pumping cycle is completed, the next time the float switch closes, the output to the lag pump in the first cycle will be energized. This provides alternation between pumping cycles. Each time a pumping cycle is complete, the pump output(s) for lead and lag will alternate.

To have the Back-Up Controller operate in the Single Float operation, only connect to float switch to the “HI” input. When the “HI” input closes without an “OFF” input closure, the Back-Up Controller will assume that the system is operating as a Single Float.

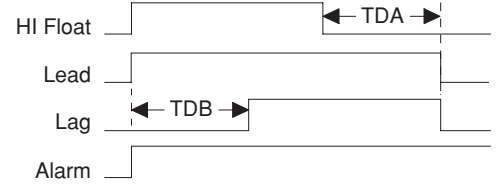

Dual Float Operation:

With power applied to the Back-Up Controller when the first float switch input closes connected to the “OFF” input, nothing happens to the outputs.

When the float switch input closes connected to the “HI” input, the output to the lead pump will be energized and Time Delay B will be initiated. If the “OFF” and the “HI” float switch inputs both remain closed and Time Delay B times out, the output to the lag pump will be energized. If the “OFF” float switch input remains closed and the “HI” float switch input opens before Time Delay B times out, the output to the lag pump will not be energized.

When the “OFF” float switch opens, the output to the pump(s) will de-energize. Once energized, the output(s) to the pump(s) remains energized until the “OFF” float switch opens.

After the pumping cycle is completed, the next time the “HI” float switch input closes, the output to the lag pump in the first cycle will be energized. This provides alternation between pumping cycles. Each time a pumping cycle is complete, the pump output(s) for lead and lag will alternate.

Whenever the “OFF” float switch input closes before the “HI” float switch input closes, the Back-Up Controller will assume that the system is operating as a Dual Float.

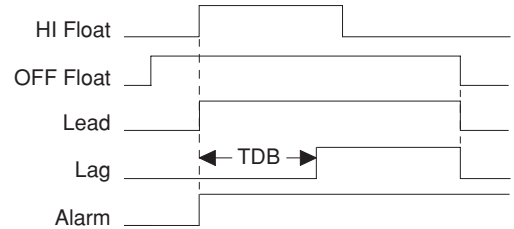

Alarm Reset:

Once the Back-Up controller has sensed a float switch input, indicating a possible failure of the transducer based system; the alarm output contact will close. To reset the alarm output contact the power must be removed from the Back-Up controller for 5 seconds and then re-applied with no float closure inputs.

DIP Switch Setting (Time Delays):

Time Delay A				Delay	Time Delay B	
Position	2 (30S)	3 (60S)	4 (120S)		Position	Delay
	Off	Off	Off	0 Sec	Off	30 Sec
	On	Off	Off	30 Sec	On	60 Sec
	Off	On	Off	60 Sec		
	On	On	Off	90 Sec		
	Off	Off	On	120 Sec		
	On	Off	On	150 Sec		
	Off	On	On	180 Sec		
	On	On	On	210 Sec		